

Technical Datasheet

BackLED L CX G4



Benefits

- High module flux up to 162 lm
- PCB and LEDs are protected inside a complete over-molded IP66 housing
- Wide beam angle for high uniformity
- Large CCT choice
- Optimal solution to reduce system cost
- Good color consistency in 3SDCM

Applications

- Backlighting of medium sized boxes and channel letters
- Permanent outdoor use in enclosed light boxes or channel letters

Technical Operating Data

Product	Color	No. of LED-modules per chain	Voltage [V DC]*	Power /module [W]*	Radiance angle [°]*	Color Temp [K]*	Lum. Flux Chain/module [lm]*
BA-L-CX 830 G4	Warm White	20	12	30 / 1.5	160	3000K	3000 / 150
BA-L-CX 840 G4	Cool White	20	12	30 / 1.5	160	4000K	3240 / 162
BA-L-CX 865 G4	Cool daylight	20	12	30 / 1.5	160	6500K	3240 / 162
BA-L-CX 871 G4	Sky white	20	12	30 / 1.5	160	7100K	3240 / 162
BA-L-CX 810 G4	North Sky white	20	12	30 / 1.5	160	10000K	3000 / 150

*) Due to the special conditions of the manufacturing processes of LED the typical data of technical parameters can only reflect statistical figures and do not necessarily correspond to the actual parameters of each single product which could differ from the typical data;
All values are tested at Ta 25 °C;

Technical Features

- LED chain comprising 20 LED modules connected by flexible cables
- Each LED module contains 3 LEDs
- Wide 160° light beam with Flat-Ray batwing lens technology
- Uniform light pattern on medium size boxes
- Optimal operation on OPTOTRONIC® 12V power supplies (15 W, 30 W, 60 W, 150 W, 300 W)
- Dimmable
- 30.000 h Lifespan – 3Y guarantee
- Full encapsulation of the LED modules with ingress protection IP66



IP66¹⁾

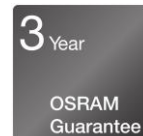

¹⁾: The LED modules must not be operated in places which are directly exposed to atmospheric conditions. For outdoor applications, hence the LED module has to be protected by appropriate sealed enclosures or covers. Operation in or under water is prohibited.

Minimum / Maximum Ratings

Product	Operating Temperature at t_c -Point [°C]*	Storage Temperature t_c -Point [°C]*	Voltage Range [V dc]*	Max case Temperature t_c [°C]*	L70B50 Lifetime [h]
BA-L-CX 830 G4	-25 ... +75	-40 ... +85	12 ... 13	+75	30.000
BA-L-CX 840 G4	-25 ... +75	-40 ... +85	12 ... 13	+75	30.000
BA-L-CX 865 G4	-25 ... +75	-40 ... +85	12 ... 13	+75	30.000
BA-L-CX 871 G4	-25 ... +75	-40 ... +85	12 ... 13	+75	30.000
BA-L-CX 810 G4	-25 ... +75	-40 ... +85	12 ... 13	+75	30.000

*) Exceeding maximum ratings for operating and storage temperature will reduce expected life time or destroy the LED Modules.
 Exceeding maximum ratings for operating voltage will cause hazardous overload and will likely destroy the LED Modules.
 The temperature of the LED modules must be measured at the t_c -point according to EN60598-1 in a thermally constant status with a temperature sensor or a temperature sensitive label.

Dimension

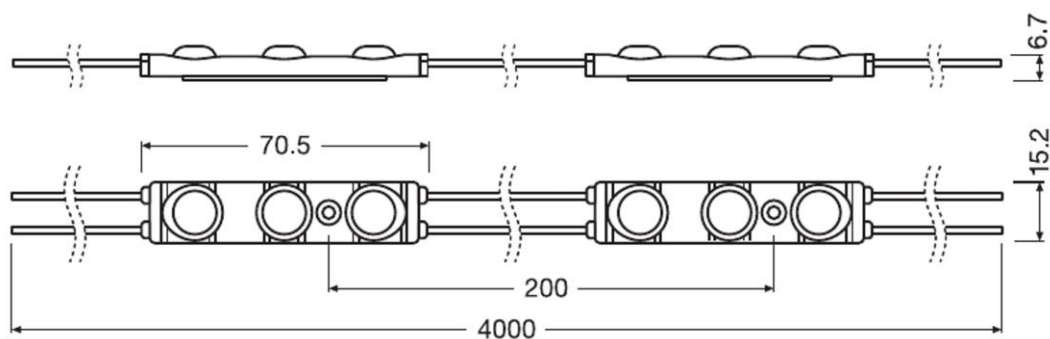

Light Distribution

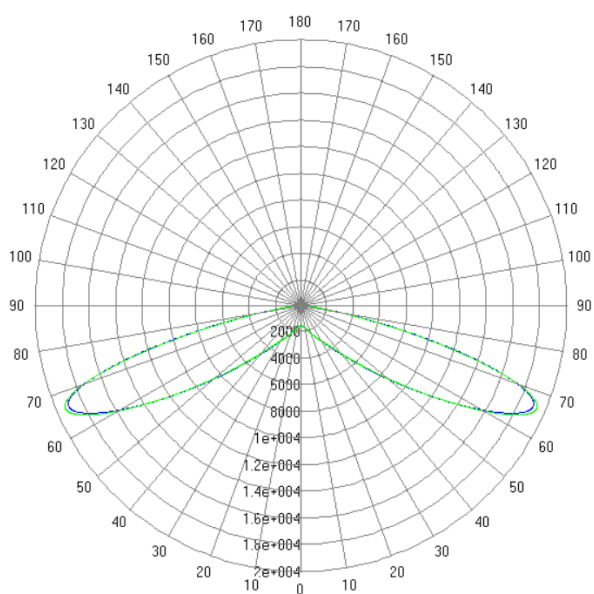

160° (±10%)
Flat-Ray Lens

Safety Information

- The LED module itself and all its components must not be mechanically stressed.
- Assembly must not damage or destroy conducting paths on the circuit board.
- To avoid mechanical damage, the LED modules should be attached securely to the intended substrate. Heavy vibration should be avoided.
- Once modules are glued by means of their tapes on the application surface, modules must not be removed and re-located. This would lead to mechanical stress and IP rate may not be granted as well as lifetime.

In order to drive OSRAM LED-Modules safely, it is absolutely necessary to operate them with an electronically stabilized power supply protecting against short circuits, overload and overheating.

For dimming applications attention should be paid to specific references in "OPTOTRONIC® Technical Guide".
To also ease the luminaire/installation approval, electronic control gear for LED or LED modules must carry the CE mark.

In Europe the declarations of conformity must include the following standards:

CE: IEC 62471, IEC 60598-1, EN 60529, EN 62031, EN 55015, EN 61547.

Also check for the mark of an independent authorized certification institute.

Please see the relevant application guides for more detailed information.

OSRAM OPTOTRONIC® electronic control gear complies to all relevant standards and guarantees safe operation.

- Installation of LED modules (with power supplies) needs to be made with regard to all applicable electrical and safety standards.
- Observe correct polarity! Incorrect polarity will lead to no light emission and may cause damage of the LED module.
- Parallel connection is highly recommended as safe electrical operation mode. Serial connection is not recommended. Unbalanced voltage drop can cause hazardous overload and damage the LED module.
- Cutting within the chain is allowed between the wiring of each module.
- Pay attention to ESD steps when mounting the module.
- When using power supplies other than OSRAM OPTOTRONIC®, in order to ensure continuous safe operation, the output voltage has to be 12.5V ±0.5V
 - A maximum of 200 modules can be operated with one OPTOTRONIC® FIT 12V 300W.
 - A maximum of 100 modules can be operated with one OPTOTRONIC® FIT 12V 150W
 - A maximum of 40 modules can be operated with one OPTOTRONIC® FIT 12V 60W.
 - A maximum of 20 modules can be operated with one OPTOTRONIC® 12V 30W.
 - A maximum of 10 modules can be operated with one OPTOTRONIC® 12V 15W.
- LED modules are dimmable by means of PWM (pulse width modulation). It is recommended using the following OSRAM control gears: OPTOTRONIC® OT DIM, OT DALI DIM, OT BLE DIM.
- The LED modules must not be operated in places which are directly exposed to atmospheric conditions. For outdoor applications, hence the LED module has to be protected by appropriate enclosures or covers. Operation in or under water is prohibited.
- Each LED module is equipped with a pre-mounted double-sided adhesive tape which allows for optional or additional mounting. Due to varying properties of adherents and multiple external influences during the operation of the modules, OSRAM assumes no liability and provides no guarantee for a permanent adherence of the modules to the surface. OSRAM recommends fixation of the modules by means of suitable screws.
- To ensure uniform illumination, a reflective matt white surface is generally recommended for all internal frame walls and back panels of light boxes.

Ordering Guide

Product group	Product name	EAN 10*	S-Unit**
BackLED L Core eXperience 830 G4	BA-L-CX 830 G4	4062172145596	30
BackLED L Core eXperience 840 G4	BA-L-CX 840 G4	4062172145619	30
BackLED L Core eXperience 865 G4	BA-L-CX 865 G4	4062172145633	30
BackLED L Core eXperience 871 G4	BA-L-CX 871 G4	4062172145657	30
BackLED L Core eXperience 810 G4	BA-L-CX 810 G4	4062172145671	30

* EAN 10: Ordering number per single unit

** S-Unit: Chain units per shipping box

Note: Typical performance data are subject to change without any further notice, particularly as LED technology evolves.

Sales and Technical Support

OSRAM GmbH
Berliner Allee 65
86153 Augsburg
Germany

www.osram.com
www.osram.com/backlighting
www.osram.com/led-designer

Sales and technical support is given by the local OSRAM subsidiaries.

On our world wide homepage all OSRAM subsidiaries are listed with complete address and phone numbers.